



Adaptatone® Millennium Central Tone Generator

*Synchronized System Signaling,
Four Outputs, RS485 Activation*

5540M Series

FEATURES

- > 27 tone capability - No additional tone modules needed
- > PLC Compatible
- > Captive Components
- > Centralized programmable tone selection
- > System-wide priority tone selection
- > RS485 models available

AGENCY APPROVALS

- > NEMA Type 3R
- > IP 44
- > UL 464 and 1604 Listed
- > UL Listed for indoor and outdoor applications in Class I, Div. 2, Groups A, B, C & D; Class II, Div. 2, Groups F & G; and Class III hazardous locations
- > cUL C22.2 No. 205 (24AQ, 24N5 & 24Y6 models)
- > TUV Rheinland Certified
- > CE Marked - Cenelec LV & EMC Directives (24Y6 AC only & 24AQ models)

SPECIFICATIONS

- > 24V DC battery backup terminals
- > Short Circuit protected

The Edwards 5540M Millennium Central Tone Generator has been designed for applications where simultaneous signaling of a high decibel, heavy duty signal is required. The tone generator assures a synchronous signaling sound from all remote speakers. The Millennium Central Tone Generator produces the 27 standard Adaptatone sounds. Four tones may be activated from field-wired, normally open contacts, or a 24VDC or 120VAC external voltage source such as an output of a PLC.

Normally open contacts can be obtained from the CatNo. 5538-4 or Cat. No. 5538-4R Adaptatone Signal Actuator See page 4-49. The tones are selected by setting miniature dip switches within the unit. The programmed tones operate on a pyramid-type priority system. For more information on priority tone operation and a complete listing of all 27 tones, see page 4-55.

On-site volume control is accomplished by adjusting the conveniently located volume control inside the unit.

The 5540M-485Y6 is designed to be connected to RS485 networks, allowing full serial signaling communication control.

Adaptatone Signaling Systems are designed for industrial applications calling for high decibel output and microprocessor reliability combined with simultaneous signal delivery over all speakers included in the system. Typical applications include: emergency warning systems, plant evacuation alarms, security intrusion sirens, process monitoring, shift start-and-dismissal horns, and paging signals.

RS485 units are MEDI compatible. See page 4-10.

D-04



TECHNICAL INFORMATION

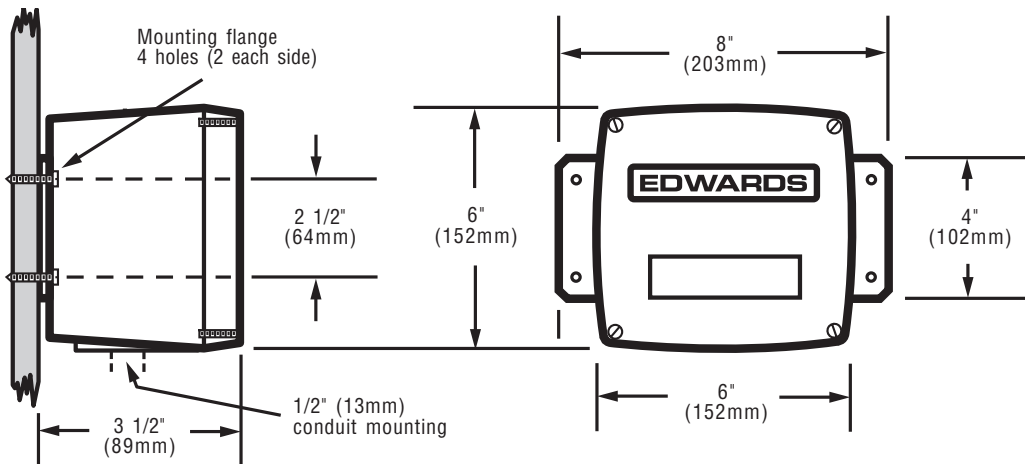

Cat. No.	Operating Voltage	Input Card Activation Voltage	Signal Off Standby Current (Amps)	Signal On Operating Current (Amps)
5540M-24AQ	24V DC	24VDC	0.10	0.74
	24V AC 50/60 Hz		0.10	1.3
5540M-24N5	120V AC 50/60 Hz	24VDC	0.10	0.36
5540M-120N5	120V AC 50/60 Hz	120VAC	0.10	0.38
5540M-24Y6	120V AC 50/60 Hz	24V DC	0.10	0.32
	240V AC 50/60 Hz		0.10	0.20
	125V DC		0.10	0.21
	250V DC		0.02	0.10
5540M-120Y6	120V AC 50/60 Hz	120VAC	0.10	0.31
	240V AC 50/60 Hz		0.10	0.20
	125V DC		0.10	0.20
	250V DC		0.02	0.10
5540M-485Y6	120V AC 50/60 Hz	RS485	0.10	0.31
	240V AC 50/60 Hz		0.10	0.20
	125V DC		0.10	0.20
	250V DC		0.02	0.10

SIGNAL INPUT LOAD CHARACTERISTICS* (PLC output to meet following product input parameters)

Cat. No.	Operating voltage	Max. off state leakage current (mA)	Continuous on current (mA)	Surge (inrush/duration) Amps/milliseconds
5540M-24AQ	24V DC only	2	740	8/4
5540M-24N5	120V 60 Hz	2	360	2.82/4
5540M-120N5	120V 60 Hz	5	380	2.82/4
5540M-24Y6	120V 60 Hz	2	320	2.82/4
5540M-120Y6	120V 60 Hz	5	310	2.82/4
24VDC Input Board	24V DC (each input)	2	6	—
120VAC Input Board	120VAC 60 Hz (each input)	5	13	—

*This device is PLC compatible and may be operated by PLCs with output characteristics that match the input load requirements of this signal.